

## CODER INSTRUCTIONS FOR UNMEI LEDS

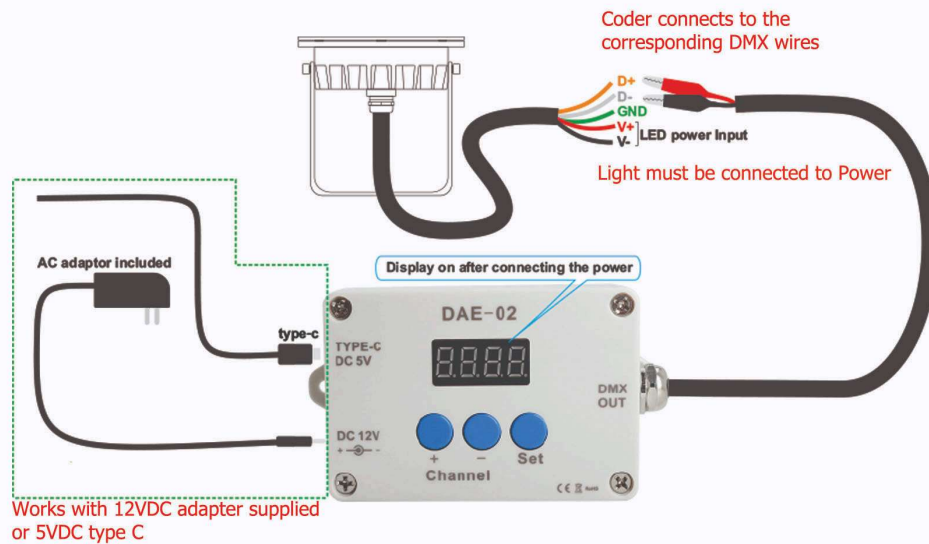

The coder is used for assigning an address to each light. Addresses can be changed or re-assigned even after programming is complete if required.

**First connect the light to be programmed to a corresponding 12VAC or 24VDC power supply to ensure you have a connection. Light should display it's internal program**

Then connect the coders signal output wires (black and red alligator clips) to each lights signal input wires. RED '+' to DMX + IN and BLACK '-' to DMX - IN.

Please ensure the correct connections are made each time.

The coder will automatically start with address 001. To assign a different address, press the + and - buttons until the desired address is shown on the screen. Once you have the new address press the 'SET' button. The light will quickly flash through each color to indicate it has received the signal and the address will be set.

The standard lights are 3 channels DMX which means after address 001, the next address to be programmed will be 004. When programming 4 channel lights (RGBW) the second address would be 005. Take the physical location in the fountain ex. Location 4, multiply by the number of channels 3 then subtract 2 (address would be 10) or multiply by 4 then subtract 3. This will give you the address of the light. \*\*\*

If you decide to change a lights location, simply attach the coder to the light you want to change and after entering the revised address press the SET button to assign the new address.

**NOTE: This is the only product that can be used to address Unmei LEDs lights**